



TRANSFORMING TECHNOLOGIES, LLC  
OUTSTANDING ALTERNATIVES IN STATIC CONTROL

TRANSFORMING TECHNOLOGIES, LLC

3407 Silica Rd.  
Sylvania, Ohio 43560

Phone: 419-841-9552  
Fax: 419-841-3241  
E-mail: [info@transforming-technologies.com](mailto:info@transforming-technologies.com)



*Ptec™* Static Eliminators

Benchtop Blower

Model IN5120



Instruction Manual

# Contents

<b>1</b>	<b>Description</b>	
	Model IN5120	1
	About <i>Plec™</i> Technology	1
	Features	1
	Power Requirements	2
<b>2</b>	<b>Operation and Use</b>	
	Environmental Conditions	2
	Set-up and Placement	3
	Power Connection	3
<b>3</b>	<b>Maintenance</b>	
	Periodic Maintenance	4
	Cleaning Exterior	4
	Cleaning Emitter Points	4
	Emitter Point Replacement	5
	Bracket Removal	6
	Service	6
	Troubleshooting	6
<b>4</b>	<b>Specifications</b>	7
<b>5</b>	<b>Service and Warranty</b>	8
<b>6</b>	<b>IN5120 Line Drawing</b>	9

## IN5120 Line Drawing

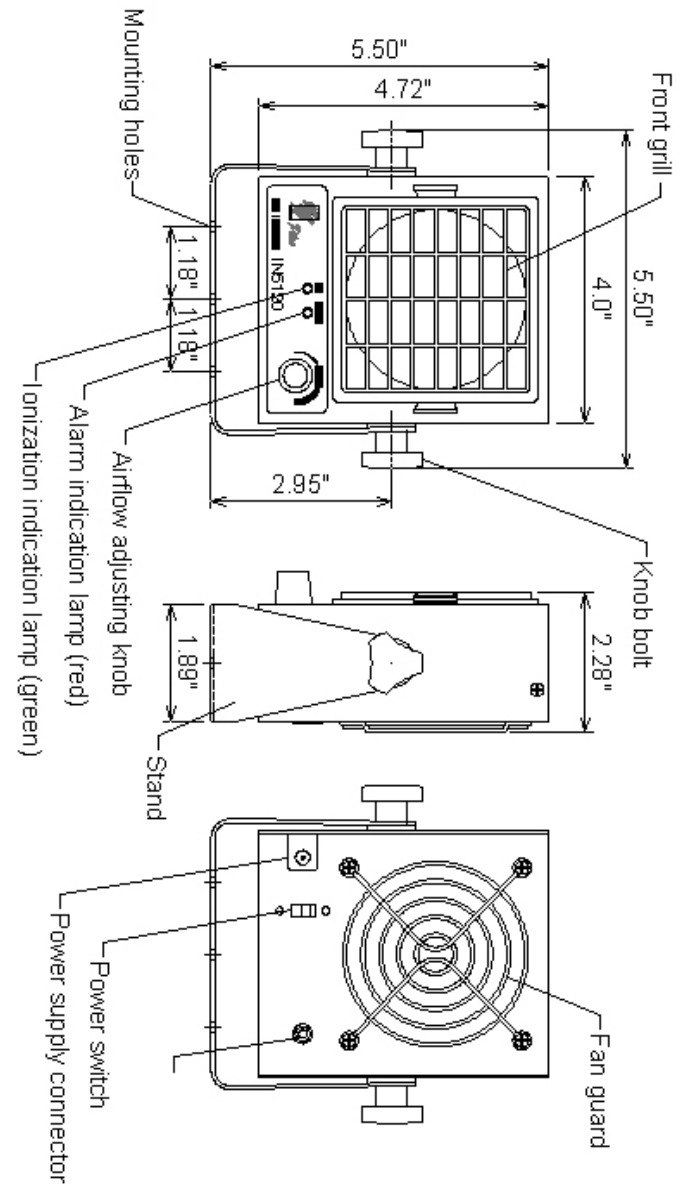

## Service and Warranty

Transforming Technologies, LLC provides a limited warranty for the Model IN5120 benchtop blower. All new products are guaranteed to be free from defects in material and workmanship for a period of one (1) year from the date of shipment. Liability is limited to servicing (after evaluating, repairing or replacing) any product returned to Transforming Technologies. The company does not warrant damage due to misuse, neglect, alteration or accident. In no event shall Transforming Technologies be liable for collateral or consequential damages.

To receive service under warranty, please contact Transforming Technologies Technical Support.

## About Transforming Technologies

Since 1998, Transforming Technologies has helped electronic manufacturing facilities to protect their products and processes from the many serious problems associated with static electricity.

Transforming Technologies offers a wide range of unique and outstanding products to detect, protect, eliminate and monitor electrostatic charges. Our products are integral components of an effective static control program.

## Description

### In-tool Ionizing Blower Model IN5120

The Model IN5120 68KHz AC in-tool air ionizer is a small, efficient static elimination device with variable fan speed for protecting electronic components and general static protection. Using AC corona technology, to make the air more conductive, Ptec™ ionizers produce a balanced stream of positive and negative air ions that never need calibration. These devices are used in many industries and manufacturing applications where static electricity is a problem.

### About *Ptec™* Technology

A specialized piezoelectric high voltage transformer makes Ptec™ ionizers among the most reliable ionizers manufactured. Small, lightweight and stable, Ptec™ products are designed to remain in balance and to alarm when the HV output affects performance. The model IN5120 benchtop static eliminator produces a 68KHz AC output of approximately 2200V and a continuous stream of balanced air ions.

Ionizers that use Ptec™ technology do not require calibration and only minimal maintenance.

## Features

On the front panel of the IN5120 are two LEDs. The green LED indicates that power is applied to the unit. The red LED is illuminated when an alarm condition occurs. A variable fan speed control, on-off switch, and removable finger guard are also on the front panel.

The rear panel of the ionizer has the 24 VDC power input connector and a grounding point.

- Physically small and light.
- Rapidly decays static charges.
- Excellent ion balance and ionization performance.
- Ionization (green) and HV alarm (red) lights.
- No periodic adjustments.
- Durable, replaceable tungsten alloy emitter points.
- Removable front grill.
- Adjustable air volume.

## Power Requirements

The Model IN5120 High frequency AC benchtop air ionizer is powered by an external DC switching power supply that operates from 100-240 VAC 50/60 Hz. The output of the supply is +24 VDC @ 500 mA.

The IN5120 blower operates on an input of +24 VDC, 7W.

## Operation and Use

## Environmental Conditions

The IN5120 can be operated in areas where humidity is 20-70% RH (Non-condensing). Excess humidity may affect ionizer performance. The temperature range for the IN5120 is 65-78°F (18-25° C).

## Specifications

<b>Power input</b>	24 VDC, 12W
<b>Power outlet</b>	unfused, 0.5A or 1.0A max.
<b>Ion Emission</b>	AC, 68KHz
<b>Balance</b>	+/- 5 volts, typical offset
<b>Decay Time</b>	1000V - 100V < 3 seconds at 1 foot
<b>Temperature</b>	66-78°F (19-25°C)
<b>Humidity</b>	20-60% RH (non-condensing)
<b>Airflow</b>	49 CFM, typical, high speed
<b>Noise level</b>	35dB(A) (Distance 1 meter)
<b>Indicators</b>	Power: green LED Alarm: red LED
<b>Controls</b>	On/Off slide switch, fan speed control
<b>Emitter points</b>	.036" dia. Tungsten alloy, etched
<b>Ozone</b>	<0.007 PPM
<b>Mounting</b>	Gimbale bracket/stand
<b>Dimensions</b>	5.5"H x 5.5"W x 2.28"D, (14.0 x 14.0 x 7.6 cm)
<b>Weight</b>	1.4lbs, (0.65kg) (including stand)
<b>AC/DC adapter</b>	Input: 100-240 VAC 50.60 Hz 0.2A      Output: + 24 VDC 1500 mA
<b>Certifications</b>	

6. Make certain the emitter points are straight and parallel to the plane of the fan.
7. Replace the front grill.

## Bracket Removal

The IN5120 in-tool ionizing blower can be removed from the universal bracket by unscrewing the side knobs. Note that there are washers located between the side knobs, stand and chassis.

## Service

Ptec™ ionizers are reliable products with a long service life. If you feel your unit is not operating properly, turn off the unit and disconnect the power cord. Contact Transforming Technologies' Technical Support for repair assistance.

## Troubleshooting

The information below provides a reference for problems that may arise with your IN5120 in-tool ionizing blower. If you have other problems not covered below, please contact Transforming Technologies' Technical Support for repair assistance

<u>Problem</u>	<u>Causes</u>
<ul style="list-style-type: none"> <li>• Balance outside specifications.</li> <li>• Alarm light activated</li> </ul>	Emitter points are dirty, damaged or not straight. Clean or replace Low HV output, call for repair Unit is arcing, call for repair Short circuit, call for repair

## Set-up and Placement

<h3>Caution</h3> <p>!</p>	<p><b>Do not use this ionizer in an explosive environment! Corona ionizers produce a weak plasma that can cause ignition in explosive environments.</b></p>
---------------------------	---

Use the IN5120 in-tool ionizing blower in proximity to a static sensitive area or object. The unit can be set on the workstation or mounted to a structure, using the u-shaped mounting bracket and hardware. Point the unit at the area to be protected.

## Power Connection

- Connect the AC adapter to the main unit, and plug it in an AC socket. **(Caution: Do not substitute another AC adapter without consulting the factory).**
- Make certain the unit is grounded.
- Turn the unit on to start the corona process. The ionizer creates a continuous stream of positive and negative air ions. The ionized airflow is directed through the front grill. Charged objects in the ionization area are rapidly neutralized .
- The ion airflow is adjustable using the fan speed control knob.
- The red alarm indicator light illuminates in the event of a problem with the high voltage power output.
- Turn the power switch off after operation.

# Maintenance

## Periodic Maintenance

<b>Caution</b> !	<b>The only serviceable parts inside the ionizer are the replaceable emitter points. Any unauthorized service will void the warranty and may result in additional repair fees.</b>
---------------------	--

The only regular maintenance required for the IN5120 is the periodic cleaning of the emitter points and ionizer grill. Emitter point cleaning affects the static decay ability of the ionizer and is important for maintaining its optimal performance.

### Cleaning the front grill and external chassis

Disassemble the front grill by squeezing the grill side clips. Temporarily remove the grill. Clean it with a polyester wiper and a cleaning solution of 50% IPA (electronic-grade isopropyl alcohol) and 50% de-ionized water. Assemble it when it is dry. Use the same method to clean the exterior of the unit, including the inlet grill.

### Cleaning the emitter points

Contaminants will gradually accumulate on the tip of the emitter points with continuous use. Periodic cleaning of the emitter points is necessary to maintain the performance of the ionizer. If the emitter points are dirty, clean them with a polyester or cotton swab and IPA. Do not damage or loosen the emitter points.

### Follow these instructions to clean the emitter points:

1. Remove the front grill.
2. Moisten a swab or wiping cloth in the IPA solution.
3. Swab or wipe the emitter points until they are free of particles.
4. Make certain the emitter points are straight and parallel to the plane of the fan.
5. Replace the front grill.
6. Make sure the emitter points are dry before powering the ionizer again.

## Emitter Point Replacement

The IN5120 uses 10 tungsten alloy precision etched emitter needles. Contact Transforming Technologies for information about ordering replacement emitters. The part number for emitters is listed below:

<u>Replacement part</u>	<u>Part Number</u>
Tungsten replacement emitters	22-6429

Because the IN5120 high voltage output is AC, emitter erosion from the ionization process on the electrodes is minimal. Unless physically broken or stressed, the IN5120 emitters should last the life of the ionizer.

### Follow these instructions to remove the emitter points:

1. Turn off and disconnect the unit from the AC power.
2. Remove the front grill.
3. Unscrew the threaded emitter point using a needle nose pliers.
4. Replace and tighten the new emitter using the same tool. Do not over-tighten.
5. Repeat steps 3 and 4 as required.